

INSTRUCTIONS

MODELS 1202 - 1250 - 1270 - 1266 INCUBATORS 110 VOLT 60-HZ 250 WATT
MODELS 1222 -1254 INCUBATORS 220 VOLT 50-HZ 250 WATT

THE 1200 SERIES CABINET INCUBATOR IS NO LONGER IN PRODUCTION. INSTRUCTION MANUAL FOR REFERENCE ONLY. SOME PARTS MAY NO LONGER BE AVAILABLE.

NOTE: It is recommended that you operate the incubator with a small quantity of inexpensive eggs to be assured of your operating procedure and the performance of the incubator before attempting to hatch large quantities of eggs or expensive eggs. (See warranty on page 6)

LOCATION

The location of the incubator is important to successful operation. A room temperature of 70° to 80° F. is ideal, and fresh air without drafts is necessary. Be sure no direct sunlight strikes the incubator and that it sits level. Keep in mind that an incubator is designed to bring normal room temperature to the desired temperature. Room temperature below 50° F. will reduce the temperature in the incubator.

TO REGULATE

IMPORTANT - Do not confuse the words THERMOMETER (the dial which shows the temperature) and THERMOSTAT (wafer, switch and adjusting screw that controls heat). These controls are located on the left side of the incubator.

Your incubator is equipped with two thermostats which are located on the side of the incubator. The one towards the front is used to regulate the temperature desired (99-1/2°) and the one towards the back is used as a safety to prevent damage to the eggs should the one in front fail. Begin by installing and adjusting the back thermostat first. **If the front thermostat is electronic, it must be turned to full increase before setting the back thermostat.**

Put the wing nut on the adjusting screw. Put the adjusting screw about three fourths of the way through the hole in the side of the incubator for the thermostat and screw. Reach inside and screw the wafer tightly onto the adjusting screw.

Next plug the cord into an electrical outlet (220-volt models will have to have a plug attached for the type outlet that is used). Turn the adjusting screw clockwise until it brings the wafer in contact with the thermostat switch and you hear a light click. Notice that the pilot light goes out when you hear this click. Now turn the adjusting screw counter-clockwise six complete turns. The pilot light and the heater are now turned on and the wafer has room to expand as the incubator heats up. The red pilot light will always be on when the heater is on and will go off when the heater turns off. Tighten wing nut after each adjustment.

As the incubator heats up, the thermostat wafer will expand and operate the switch turning off the heater and pilot light. During normal operation the light and heat will cycle on and off frequently. While the incubator heats up, watch the thermometer. As soon as it registers 102°F (or 2°F. above the operating temperature) turn the adjusting screw clockwise very slowly until the pilot light goes out. If the incubator temperature does not reach 102°F before the pilot light goes out turn adjusting screw counter-clockwise until the temperature does reach 102°F or until the pilot light turns on.

Adjust in this manner until you have the incubator regulated to hold at 102°F. Operate for at least 30 minutes at this temperature to be sure it holds this temperature.

Once the back thermostat is regulated at 102°F, open the door and install the wafer in the front thermostat. Regulate the front thermostat for 99-1/2°F in the same manner as for the back thermostat. If the front thermostat is electronic, simply turn the adjusting stem clockwise until the incubator is reduced to the desired temperature. The pilot light will cycle quickly.

THE CORRECT TEMPERATURE FOR MOST EGGS IS 99-1/2°F DURING SETTING AND THIS TEMPERATURE SHOULD BE REGULATED WITH THE FRONT THERMOSTAT. The back thermostat is a safety to prevent excessive overheating of the eggs (should the front thermostat fail in the heating mode) and should not be touched once it has been set. Should it be bothered repeat the regulating process.

Now that the incubator is regulated, slight adjustments can be made with the front thermostat. Check the temperature several times each day and if it is 102°F, then the front thermostat may have failed and should be replaced. The back thermostat can be used to bring the temperature down to 99-1/2°F until a replacement switch can be obtained.

Another type of switch failure can cause the incubator to stop heating. This type of failure usually is noticed during the first few weeks of incubation. This failure is confirmed when both thermostats are turned to full increase so that the wafer does not contact the switch and the pilot light and heater do not come on.

Switch failures are rare and your unit may never have one. Many failed switches may start to work again if tapped or bumped, but do not allow this type of switch to remain in service. Replace it promptly.

TO CHANGE THERMOSTAT SWITCH

Unplug electric cord from wall socket. Remove two screws holding switch in thermostat bracket. This will permit switch to

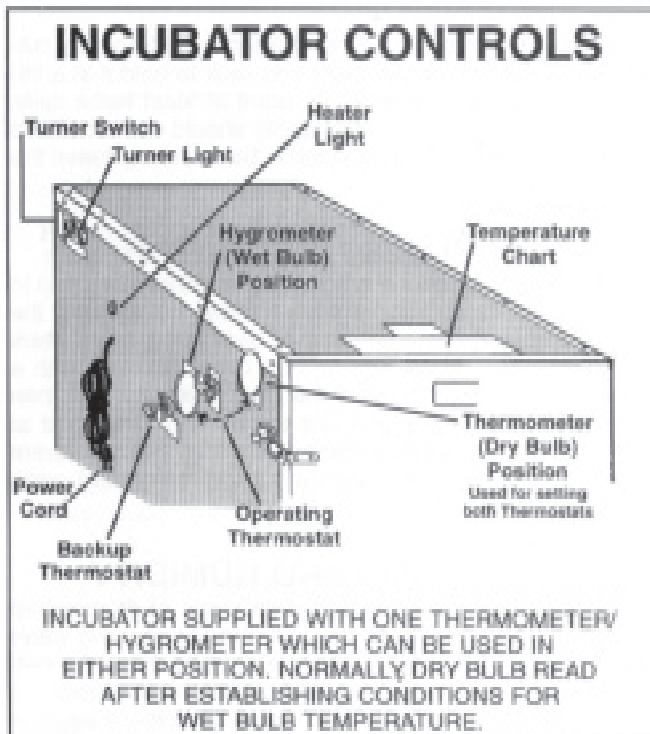

be removed from bracket. Remove screw holding one wire to switch and attach to new switch in same position. Remove screw holding other wire and attach to new switch. Put new switch into bracket just like you removed the old one and adjust temperature again to 99-1/2°F. (It is wise to have a couple of spare switches on hand, No. 3006)

SETTING AND TURNING EGGS

Eggs must be fresh and fertile. Do not use eggs over 16 days old and best results are obtained if eggs are less than 10 days old. Percentage of hatch will drop a little each day during storage. Eggs being saved for incubation should be protected from excess heat and freezing. Ideal storage temperature is 55°F and under moist conditions. Air cooled by air conditioners can be too dry for storage. Discard small or poorly shaped eggs and any cracked, thin or porous shells. Set only eggs that are clean and of uniform size.

When cold eggs are placed in the incubator, allow extra time for the incubator to get up to operating temperature.

For quail eggs, the incubator comes with sample paper mache egg trays that are used to position the eggs in the turning trays. Using a knife, cut or tear off the top and bottom of each peak of the egg positioners. This will allow more air circulation when the eggs are double stacked. Double stacking of quail eggs allows for maximum capacity by placing four egg trays in the incubator tray and then placing another egg tray on top of each tray.

For small quantities of larger eggs such as chukar, pheasant or chicken, egg positioners can be made from the dozen size egg carton which comes from the grocery store. Cut off the top of the carton and cut holes in the bottom for air flow. No. 0200 Chicken egg tray can be ordered from G.Q.F. Mfg. Co. It is paper mache and holds 30 eggs. Also, No. 0229 Chukar egg tray can be used for pheasant and chukar. Press the peaks between thumb and forefinger to make more room for pheasant eggs. The best positioners are the plastic type shown in the G.Q.F. catalog.

A greater quantity of the larger eggs may be put in the incubator by propping the incubator tray at a 45 degree angle. Place the eggs in rows with the small end down towards the wire bottom of the tray. Pack wads of paper at the end of the rows to hold eggs firmly in position.

If the automatic turner is not used then eggs should be turned at least twice daily.

OPERATION OF AUTOMATIC TURNER

Controls for the operation of the turner are located on the left rear side of the incubator. The switch has three positions. Center position is OFF. Up position is MOMENTARY ON and switch is spring loaded so that it turns off when released. Down position is ON and is the normal operating position. Pilot light remains on when turner switch is in down operating position.

To operate, open the door of the incubator so that you may observe the trays. See that the egg trays are pushed all the way to the back before operating the turner or they may be jammed during turning which may cause some damage. Push the switch to the MOMENTARY ON position and hold it on until the trays are level. If you should run past level, you will have to let the trays run until they go all the way over and back to level again. There is no reverse on this turner. The trays may then be removed for loading with eggs and returned into the incubator. Be sure trays are pushed all the way back into the rack. Check operation through entire cycle of tilt with the momentary switch.

Next move the switch to the ON position. The timer switch may do one of two things. It may tilt the eggs to one side and leave them there for part of an hour or it may leave them sitting level for part of an hour and then turn them to one side. After the first tilting of the eggs, the timer will then change the tilt from one side to the other in approximately two hour cycles.

TEST FOR ASSURANCE THAT TURNER IS WORKING. If it appears that the trays are always tilted to the same side when you open the door and you have any doubts that the turner is operating, then you can test for operation. **Run the turner until the trays are level and return the switch to the ON position. Look to see if the trays remain level. If not, then re-level so that they remain level. Put the switch in the ON position. Check the tray level after two hours. If trays are not level then the turner is operating properly.**

The No. 3021 turner is a very reliable turner and should give years of trouble free operation. However, if any problems should develop, you may want to contact GQF for advice or assistance or the turner may be returned for inspection or repair. If it is necessary to remove the turner then the back and top of the incubator must be removed.

UNPLUG THE ELECTRIC CORD BEFORE REMOVING THE BACK OR TOP OF THE INCUBATOR.

To remove the turner, unscrew the lock nut that holds the connecting bar to the turner swing arm. Remove the connecting bar and put washer and nut back on bolt of swing arm. Remove wood screws holding the turner to the shelf and incubator side. Remove wood screws holding the switch plate on the side of the incubator. Disconnect the two wires from the power source going to the turner. The turner should now be free of the incubator.

When returning the turner for repairs, pack in a sturdy carton with packing for protection. Also, enclose payment for \$10.00 for inspection and return postage, your name, address, phone number and advise the problem that you are having. Send the turner by mail or UPS and have it insured.

The incubator may be operated without the turner by cutting blocks to fit under the lower tray rack to hold it in a tilted position. Rotate the racks by hand at least twice daily. Opening the door several times a day should do no harm to the eggs as under natural conditions the hen may leave the nest and return.

MODEL 1250 INCUBATOR

Although designed as a hatcher, the 1250 can be used to set eggs also. To do this, remove the tray covers until time of hatch. Lay the eggs on their side in the trays. Mark an X on one side of the egg and an O on the other with a pencil. Hand turn so that all of the X's are up one time then the next time turn so that all the O's are up. Turn the eggs at least twice a day, but three times would be best. Different settings of eggs may be separated with cardboard partitions.

VENTILATION AND HUMIDITY

It is necessary for the egg to lose some of its moisture during incubation; however, the purpose of supplying water in an incubator is to prevent excessive drying out of the natural moisture in the egg. The rate of evaporation from the egg is judged by either the size of the air sack in the egg, the hygrometer reading, or by weighing with a gram scale. Weighing the eggs with a gram scale is the best way of determining proper humidity. Eggs should lose 12% to 14% of their weight during incubation.

TESTING

Most eggs can be candled by shining a bright light through an egg while in a dark room. This allows the viewer to see if the eggs are fertile (only after seven days of incubation). Fertile eggs will be dark and will show the outline of the air sack. If the air sack is too large for the stage of incubation then moisture must be added, or reduce moisture if too small. The diagram illustrates the proper air spaces at different stages of incubation in a chicken egg. This method requires that the operator be observant and have sufficient experience to properly judge the air sack.

The beginner may find the best results by using directed vent settings and/or using recommended hygrometer settings for the type of eggs being hatched. The HYGROMETER is a thermometer with a wick on it that is kept wet to give a "wet bulb temperature." The incubator's dial thermometer can be used as a hygrometer.

To use the thermometer as a hygrometer is a simple matter. Once the incubator has been regulated for 99- $\frac{1}{2}$ °F. (so that when the door has been opened it will return to that temperature without being regulated) then move the thermometer from its position labeled thermometer to the hole that is labeled hygrometer. Inserting the thermometer in this hole will put the probe just above the moisture pan. Next, wet one wick and open the end of it (the wick is a cloth tube, like a sleeve) and slide it over the probe. The wick should be covering three inches of the probe and the other end of the wick should be in the water of the moisture pan. When the door of the incubator is closed, the temperature in the incubator should return to 99- $\frac{1}{2}$ °F within 15 minutes. Check the hygrometer for the wet bulb temperature. Make adjustments for moisture (see below) until the recommended setting is obtained. Once the proper humidity is reached remove the hygrometer wick then move the thermometer back to the thermometer position.

The two most common means of controlling the humidity in the incubator are by using the VENTS and/or the MOISTURE PAN. New 1202 models 3 inlet vents at the top and 3 exit vents at the bottom of the incubator. Begin with all vents closed except the center top and center bottom vent, which should be open halfway. Ostrich and emu eggs usually require all six vents to be fully open.

The humidity pan should be cleaned before first use and after each hatch. The pan should be filled with **warm** water and maintained at a level approximately $\frac{1}{2}$ to 1 inch from the top of the pan. We recommend using the Automatic Water System (part No. 3030) to maintain constant water level. Center the pan on the shelf. **Do not install the humidity pad at this stage.** In most conditions the humidity pad will not be used until the hatching phase of the process.

Allow the incubator to run with the vents set properly and the pan filled with warm water for 1 hour, this will allow time for the humidity to stabilize. Once the humidity has stabilized, make small adjustments to the center vents as needed to provide the desired humidity. Opening the vents will lower humidity and closing the vents will increase humidity. **Caution: Do not close vents completely.** In some conditions, such as high altitudes, it may be necessary to use the humidity pad throughout the entire hatch to achieve the desired humidity.

During the hatching phase of the process additional humidity is necessary. Under normal conditions, this is the stage in which the humidity pad will be added to the pan. If extremely high humidity conditions are desired, 2 humidity pads are used. The center vents can be adjusted for fine tuning of humidity. See label on top of incubator for suggested temperatures and humidities.

If you have white, clear shelled eggs, such as leghorns or mimorcas, they can be tested on the third or fourth day, but if they are dark shelled eggs such as plymouth rock, etc. it is hardly worth while to test them before the sixth or eighth day. The room should be quite dark to enable you to see them clearly. Hold the egg with the large end uppermost to a tester light, looking through the side of the egg and slowly turning it in the hand. To make a homemade egg tester, get a small paper or corrugated box into which you can insert a light bulb attached to a drop cord and cut a small hole in the top or end of the box. Place the large end of the egg against this hole and the light will show into the egg enabling you to see whether or not it is fertile. If the eggs are fertile, a small dark spot with a mass of little blood veins extending in all directions will be seen floating inside the egg. This is known as the embryo. If the fertility is not strong, the embryo will have already died, the blood settling away from the embryo toward the edges of the yolk. All such eggs, or any eggs that are perfectly clear, should be removed from the incubator. These eggs can be boiled hard and used for feeding the chicks.

When testing the eggs for fertility, notice very carefully the size of the air space in the large end of the egg. At the time of the seventh day test, this space should be no larger than a 25-cent peice (on chicken eggs). The second fertility test should be made on the fourteenth day of incubation. Some of the embryos which looked strong and healthy at the time of the first test may have weakened and died. These and all eggs with "blood rings" or blood spots should be immediately removed, to prevent dead eggs from contaminating incubator air. Eggs air space at the fourteenth day test should be no larger than a 50 cent peice. If larger, provide more moisture, unless weighing shows different.

HATCHING

Three days before the total incubation and hatching time the incubator should be prepared for hatching. Eggs must be moved to hatching trays, in the bottom of Models 0802 and 1202, or into separate hatcher such as Model 1250. The eggs should lie on their sides in the hatching trays with the small end slightly lower than the large end. Do not over crowd the eggs in the hatching tray. To make more room, candle and throw out the infertile eggs. When hatching quail eggs and small game birds use the hatching tray covers to keep the chicks from getting all over the incubator. Leave tray covers off for chicken and larger birds

IMPORTANT - Increase humidity for hatching by adding the second pan of water to the fan shelf or a humidity pad if using the 3030 tank. Lower the operating temperature one degree to 98- $\frac{1}{2}$ °F. The hygrometer reading should come up to the 88° to 90° range when the extra pan is added. Close the vents slightly if necessary to increase hygrometer setting. When hatch is complete, return the incubator to the proper setting temperature and humidity.

Remove chicks to the brooder 24 hours after hatching or when dry. Wet chicks may catch cold when out of the incubator. If some of the eggs are late in hatching, removal of chicks should be done quickly as possible to prevent chilling of the unhatched eggs. If any of the remaining eggs appear hatchable, continue running the incubator for three to five days.

IF EGGS HATCH A DAY OR TWO EARLY, DECREASE THE TEMPERATURE 1/2° DURING THE ENTIRE INCUBATION PERIOD ON THE NEXT SETTING. IF THE EGGS HATCH A DAY OR TWO LATE THEN INCREASE THE TEMPERATURE 1/2°.

BROODING

Remove chicks to the brooder within 24 hours after hatching as soon as they are dry. If some of the eggs are late hatching, removal of chicks should be done quickly as possible to prevent chilling of unhatched eggs. If some eggs appear hatchable, continue the hatch for a day or two more. Chicks hatching a few days beyond expected date are usually weak and may not survive. Discard eggs that are over four days beyond hatch date.

When chicks are removed from the incubator they must have a place that is warm and dry. A brooder should have one section that is heated, with a temperature of 100F (37C) for small birds like quail or 95F (34C) for larger birds like chickens. Maintain this temperature for the first week and then lower it 5 degrees (F) each week there after down to normal room temperature. If temperatures are a little too warm the chicks will move to the cooler parts of the brooder on their own. Place food on a flat surface near the feeder. Avoid slick surfaces like cardboard, plastic or flat newspaper as young chicks have difficulty standing on them. Water should be available in a proper drinker for the type chicks. Small birds such as quail can easily drown in large drinkers so rocks or marbles may need to be used at first if the drinker is not made especially for them. The GQF catalog has suitable brooders, feeders and drinkers. GQF Vitamins Plus is also recommended for the first seven days to improve survivability.



G.Q.F. has many types of brooders, feeders, and waterers available

CLEANING AND SERVICING

If practical, the incubator maybe wiped down with a disinfectant such as Tek-Trol. Even a mild detergent maybe used and the trays placed in strong sunlight to dry. There is aluminum clean out pan on the floor of the incubator, which should be cleaned after each hatch. Moisture pans and tanks should also be cleaned from time to time. Hygrometer wicks and wick pads may begin to turn brown from mineral stains. These maybe used again by placing the stained portion into the water. Wicks and pads can only be used a few times and then must be replaced.

Cleaning and repairs in the rear of the incubator can be done by first unplugging the incubator from the power and then removing the screws from the back panel. Carefully wipe away any feather dust with a moist sponge. Replacement parts are available from GQF. The fan motor is sealed and does not require oiling. Thermostats and turner parts should give long service but parts are available when needed.



Tek-Trol, available from G.Q.F. can be used to sanitize incubators and hatchers.

ACCESSORIES



No. 0243

EGG RACK POSITIONERS FOR CABINET INCUBATORS

Plastic egg rack positioners offer the most efficient system for gathering, spray disinfectant treating and storing of eggs. At time of setting eggs, just remove loaded egg rack positioners from storage area to the incubator setting trays.

No. 0243 - SET OF 6 QUAIL EGG RACKS, each No. 1502 setting tray will hold 2 egg racks (248 quail eggs) for a total of 744 eggs per incubator (racks single stacked). Molded posts on each rack permits double stacking for a total of 1488 quail eggs. (Caution: GQF HATCHING trays hold a maximum of 250 quail eggs).

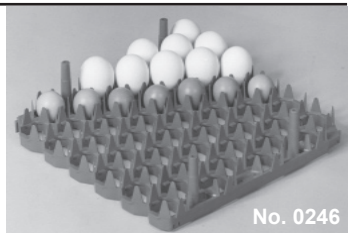

No. 0246

No. 0245 - SET OF 6 PHEASANT EGG RACKS, each rack holds 59 eggs, for a total of 354 eggs per 1502 incubator.

No. 0246 - SET OF 6 UNIVERSAL EGG RACKS, each rack holds 45 bantam to chicken sized eggs, for a total of 270 eggs per 1502 incubator.

No. 0248 - SET OF 6 EXTRA-LARGE EGG RACKS, each rack holds 30 extra large eggs (Turkey, Duck, etc.), for a total of 180 eggs per 1502 incubator.



AUTMOTATIC INCUBATOR HUMIDITY

Consists of 5 Gal. reserve tank, connecting hose, with quick disconnect coupling and constant level humidity pan with 2 humidity pads, for increased humidity at time of hatch. For all GQF Cabinet Incubators.

No. 3030 - Automatic Incubator Humidity

No. 4502 - Pkg. 2 Extra Humidity Pads

No. 4510 - Pkg. 10 Extra Humidity Pads

CLEAR ACRYLIC DOOR FOR ALL CABINET MODEL INCUBATORS AND HATCHERS

CLEAR ACRYLIC DOOR gives full frontal view of interior of incubator, to permit checking of hatching progress, tray turning, water level, etc.

No. 3065 - Clear Acrylic Door 31 1/4" x 15 1/2" x 1/2" - Sold as an accessory for customer's installation only.



ORDER ACCESSORIES BY PHONE: 912-236-0651 - OR - ON THE INTERNET AT WWW.GQFmfg.COM

GENERAL INCUBATOR OPERATING INSTRUCTIONS FOR SEVERAL SPECIES OF BIRDS

Requirements	Bobwhite Quail	Coturnix Quail	Ostrich	Emu	Rheas	Duck	Muscovy Duck	Goose	Guinea	Pheasant	Peafowl	Chicken, Bantam	Turkey	Chukar Partridge	Grouse	Pigeon
Incubation period (days)	23-24	17	42-48	43-50	35-40	28	35-37	28-34	28	23-28	28-30	21	28	23-24	25	17
Temperature (F)	100	100	96.5-97	96.5-97	96.5-97	100	100	100	100	100	100	100	100	100	100	100
Humidity (wet bulb, F)*	84-86	84-86	70	70	85-87	84-86	84-86	86-88	83-85	82-84	83-85	85-87	83-85	80-82	82-86	84-86
Final day of egg rotation	21	15	38-40	44-46	30-33	25	31	25	25	21	25	19	25	21	22	15
Temperature during final 3 days of incubation (F)	99.5	99.5	96-96.5	96-96.5	98.5	99.5	99.5	99.5	99	99.5	99.5	99.5	99.5	99.5	99.5	99.5
Humidity during final 3 days of incubation (wet bulb, F)	90-94	90-94	75	75	88-90	90-94	90-94	90-94	90-94	92-95	90-94	90-94	90-94	90-94	90-94	90-94

* % Weight loss: Total weight loss from beginning to end of Incubation should be 12%-15% for most eggs

$$\% \text{ Weight Loss} = \frac{\text{Original wt.} - \text{Present wt.}}{\text{Original wt.}} \times 100\%$$

$$\text{Average Daily Wt. Loss Required} = \frac{\text{Original wt.} \times .14}{\text{Incubation Period}}$$

Diagram of incubator turner.
Complete turner is item No. 3021

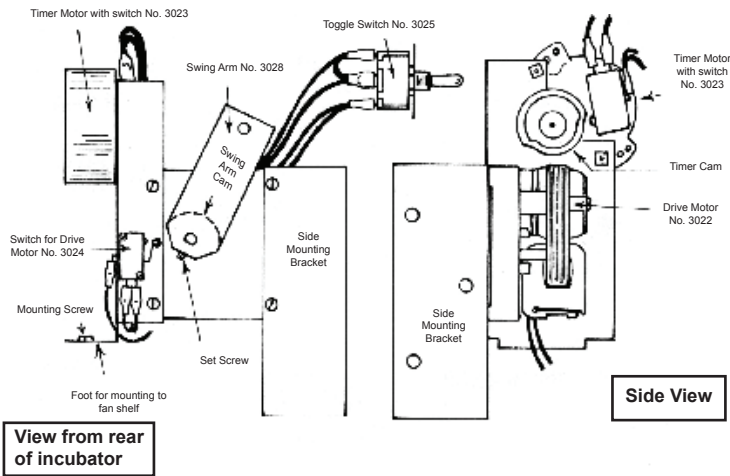

TURNER PROBLEM CHECK LIST

PROBLEM	CHECK FOR:
Turner fails to turn automatically but will turn manually.	1—TEST FOR ASSURANCE THAT TURNER IS WORKING as shown on Page 1 of Incubator Instructions. 2—Remove back of incubator. DO NOT TOUCH ANY PART OF TURNER WHILE INCUBATOR OR TURNER IS PLUGGED INTO POWER. Check to see if turner light comes on when switched to Automatic. If not, check for loose wires or connections at toggle and other switches. Check all slip on connections for good contact. If Timer Cam marks do not show signs of rotating in 30 minutes or if Timer Switch seems defective, No. 3023 Timer with Switch will need to be replaced.
Turner fails to turn on manual or automatic	1—Check to be sure trays inside have not been pushed all the way to back or some other obstruction that has jammed the trays. 2—Be sure incubator and turner is plugged into outlet that has electric current and that pilot light is on when switched to automatic. 3—Remove back of incubator. DO NOT TOUCH ANY PART OF TURNER WHILE INCUBATOR IS PLUGGED INTO POWER. Check for loose wires, loose connection rods or jammed tray.
Turns constantly when switched to automatic	1—Switch for Drive Motor is loose and has moved away from Swing Arm Cam. Loosen screws holding Switch, push switch closer to Cam and while holding it closer to Cam, tighten screws. Avoid over tightening as you could break switch housing.

CONVERSION OF WET/DRY BULB READINGS TO PERCENT OF RELATIVE HUMIDITY

		DRY BULB TEMPERATURES									
		85	90	95	96	97	98	99	100	101	102
WET BULB TEMPERATURES	68	41	31	23	22	21	19	18	17	16	15
	69	44	34	25	24	23	21	20	19	18	17
	70	47	36	28	26	25	23	22	21	20	18
	71	50	39	30	28	27	25	24	23	21	20
	72	33	41	32	30	29	27	26	25	23	22
	73	56	44	34	33	31	30	23	27	25	24
	74	60	47	37	35	33	32	30	29	27	26
	75	63	50	39	37	36	34	32	31	29	28
	76	66	53	42	40	38	36	34	33	31	30
	77	70	55	44	42	40	38	37	35	33	32
78	73	58	47	45	43	41	39	37	36	34	
79	77	62	49	47	45	43	41	39	38	36	
80	80	65	52	50	48	46	44	42	40	38	
81	84	68	55	53	51	48	46	44	42	40	
82	80	71	57	55	53	51	48	46	43	43	
83	92	74	60	58	55	53	51	49	47	43	
84	96	78	63	61	58	56	54	51	49	47	
85	100	81	66	64	61	59	56	54	52	50	
86		85	69	67	64	61	59	57	54	52	
87		89	72	70	67	64	62	59	57	55	
88		92	76	73	70	67	65	62	60	57	
89		96	79	76	73	70	67	65	62	60	
93		100	82	79	76	73	70	68	63	63	
91			86	82	79	76	73	71	68	65	
92			89	86	83	79	76	74	71	68	
93			93	89	86	83	80	77	74	71	
94			96	93	89	86	83	80	77	74	
95			100	96	93	89	86	83	80	77	

NOTE: The above chart is for sea level readings. A general rule of adjustment would be to add 1 to the percent value shown in the body of the chart for each 2500 feet of elevation above sea level.

*To obtain lower wet bulb readings, recommended for ratite eggs, we recommend using an inexpensive room dehumidifier, available at Sears, WW Grainger and other outlets.

INCUBATION TROUBLESHOOTING CHART

Symptoms	Probable Causes	Suggestions
Many clear eggs. No blood (Determined by candling, then broken out appearance)	1. Infertility. Too few males, too many males, males too old, inactive, or frozen combs 2. Embryo died early 1-2 days	1. Use young, vigorous males. 2. Do not hold eggs longer than 14 days. Keep at temperatures of 50°-55°F. in moist atmosphere. Gather often.
Slight blood rings	3. A. Improper temperature B. Fumigation 4. Improper care of eggs before setting	3. A. Check accuracy of thermometer, Check thermostat, heating element, current supply. Check operating temperature against instructions. B. Do not fumigate at high concentrations during the first 5 days of age. 4. See suggestions (2) above.
Many dead germs	5. Temperature too high or too low 6. Improper turning of eggs 7. Improper feeding of flock 8. Breeding (low hatchability inherited) 9. Improper ventilation, insufficient oxygen	5. See suggestion (3) above. 6. Turn two times daily - same time morning & evening 7. Check vitamin and mineral content of breeder mash. 8. Avoid close inbreeding 9. Increase ventilation of incubator and incubator rooms, avoid draft
Pipped eggs not hatching Hatch non-uniform Hatching too early Hatching too late Sticky Hatch	10. Insufficient moisture 11. Too much moisture 12. Too low temperature 13. Too high temperature	10. Increase humidity during incubation (wet bulb 82°-86°) add wick pad last 3 days (wet bulb 90°-92°) during hatching time 11. See (3) above and see "Hatching" page 3 12. See (3) above and see "Hatching" page 3 13. See (3) above and see "Hatching" page 3
Cripples and Malpositions	14. Temperature too high 15. Too low moisture 16. Improper turning or setting 17. Hatching trays too smooth	14. See (3) above and see "Hatching" page 3 15. See (10) above 16. See (6) above. Set eggs large end up. 17. Use wire bottom trays or crinoline
*Very large, soft-bodied weak chicks Mushy chicks. Dead on trays, bad odor	18. Low average temperature 19. Poor Ventilation 20. Navel infection in incubator	18. See (3) above and see "Hatching" page 3 19. See (9) above 20. Careful cleaning and fumigation of incubator between hatchings.
Rough navels	21. High temperature or wide temperature variations. 22. Low Moisture	21. See (3) above 22. See (10) above
Temperature reading not constant	23. Incubator in unheated room or barn where temperature varies 24. Improper adjustment of thermostat (can be caused by someone tampering with adjusting knob	23. Keep Incubator In room with uniform temperature and where temperature is never below 50°. 24. Readjust thermostats. Make slight adjustments with adjusting knob and wait 15 minutes for temperature to stabilize.
Incubator fails to heat (Continue hatch if begun. Hatch may occur later than expected because of temperature drop.)	25. Thermostat failure 26. Improper setting of thermostat 27. Power failure, incubator unplugged or poor plug connection 28. Loose wire connection	25. switch to back up thermostat 26. Turn adjusting knob to increase heat until pilot light comes on. 27. If fan is not running, electricity is not getting to incubator check fuses and plug connections. 28. Remove back of incubator and check for loose wires.
Fan Rattles	29. Blade bent 30. End play in motor shaft	29. Remove and straighten blade or replace with new blade 30. Place block under back legs of Incubator
Hygrometer reading above 94°	31. Dry wick on hygrometer	31. Wash calcium deposits from wick or replace with new wick.

PLEASE NOTE: DIAGRAM AT RIGHT SHOWS OLDER 1500 SERIES AND IS FOR REFERENCE ONLY. 1200 SERIES DIAGRAM NO LONGER AVAILABLE. MOST PARTS BELOW SHOULD APPLY TO 1200 MODELS.

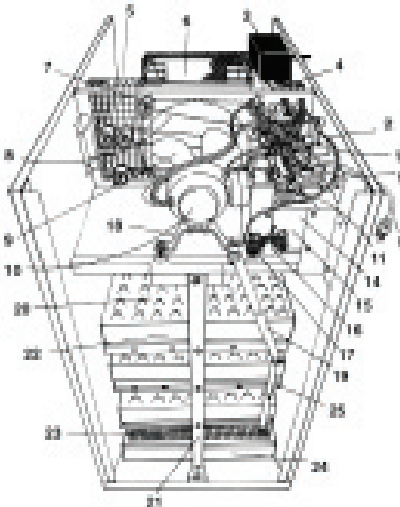

Reference Number	Catalog Number	Reference Number	Catalog Number
1 - POWER CORD.....	No. 3048	14-DRIVE MOTOR.....	No. 3022
2 - PILOT LIGHT.....	No. 3017	15 - AUTOMATIC TURNER.....	No. 3021
3 - WAFER THERMOSTAT.....	No. 3122	16 - SWING ARM WITH CAM.....	No. 3028
4 - Aux. THERMOSTAT.....	No. 3122	17 - ROLLER Switch for Drive Motor.No.	3024
5 - HEATER GUARD		18 - FAN MOUNT.....	No. 3026
6 - MOISTURE PAN/PAD(S).....	No. 4500	19 - CONNECTING BAR.....	No. 3041
7 - PORCELAIN INSULATOR		20 - QUAIL EGG POSITIONERS.....	No. 0205
8 - HEAT ELEMENT.....	No. 3014	21 - BACK SUPPORT.....	No. 3042
9 - FAN BLADE.....	No. 3013	22 -1502 SET. TRAY - 24.5" x 12.75.No.	3067
10-FAN MOTOR.....	No. 3011	23 -1550 TRAY CVR.-25" x 14.25".....	No.3068
11- TIMER WITH SWITCH.....	No. 3023	24 -1550 HATCH TRAY - 24.5"x14".....	No. 3066
12-TURNER LIGHT.....	No.3017	25 -1502 SET TRAY RACK/23".....	No. 3069
13-TURNERTOGGLE SWITCH.....	No.3025		

LIMITED WARRANTY

GQF Mfg. Co., Inc. guarantees against defect for a period of 1 year from date of purchase. Notify GQF Mfg. Co. of any defective items, giving catalogue number and name of item and just what is wrong with item. Send copy of invoice showing date of purchase. GQF Mfg. Co. will send replacement or notify regarding return. Returning of items without written permission will be at owner's expense.

Whereas GQF Mfg. Co. has no control over usage of equipment supplied, it assumes no responsibility for losses or damage from their equipment other than replacement of defective parts. No guarantee on hatchability of eggs. Do not expose electrical parts to water. Installation of electrical parts should be done by qualified electrician.

G.Q.F. Manufacturing Company

P.O. Box 1552
www.GQFMFG.com

Savannah, GA 31402-1552 USA